

IDEAL 4810-95
IDEAL 4810-95EP



IDEAL 4850-95
IDEAL 4850-95EP



IDEAL 5221-95EP



IDEAL 6550-95EP



- Sicherheitshinweise • Safety precautions •
- Consignes de sécurité • Veiligheidsvoorschriften •
- Misura di Sicurezza • Normas de Seguridad •
- Säkerhetsföreskrifter • Turvallisuusohjeita • Sikkerhedsforskriftene •
- Środki bezpieczeństwa • Меры предосторожности •

IDEAL 4810-95/EP • IDEAL 4850-95/EP • IDEAL 5221-95EP • IDEAL 6550-95EP



- D** Bitte lesen Sie vor Inbetriebnahme der Maschine unbedingt diese Betriebsanleitung und beachten Sie die Sicherheitshinweise. Die Betriebsanleitung muss jederzeit verfügbar sein.
- GB** Please read these operating instructions before putting the machine into operation and observe the safety precautions. The operating instructions must always be available.
- F** Nous vous prions de lire attentivement le mode d'emploi avant d'utiliser la machine, et attirons votre attention sur les consignes de sécurité. Les instructions d'utilisation et les consignes de sécurité doivent toujours être disponibles. Les instructions d'utilisation et les consi.
- NL** Leest u voor de ingebruik name van het apparaat a.u.b. deze gebruiksaanwijzing goed door en neemt u de veiligheidsinstructies n acht. De gebruiksaanwijzing en de veiligheids-voorschriften moeten altijd binnen handbereik zijn.
- I** Per favore legga questo manuale di istruzione prima di mettere in funzione il distruggidocumenti e osservi le regole di sicurezza. Le istruzioni d'uso devono essere sempre disponibili.
- E** Le recomendamos lea las instrucciones antes de poner en funcionamiento esta máquina y cumpla las normas de seguridad. Las instrucciones de servicio y seguridad deben estar siempre disponibles.
- S** Läs igenom denna bruksanvisning innan ni startar maskinen. Var noga med säkerhetsföreskrifterna. Instruktionsmanualen måste alltid finnas tillgänglig.
- FIN** Lue nämä käyttö-ohjeet läpi ennenkuin käynnistät laitteen !
Noudata turvaohjeita. Käyttöohjeiden on oltava aina saatavilla.
- N** Lees gjennom denne bruksanvisningen før De tar i bruk maskinen Vær oppmerksom på sikkerhetsforskriftene. Operatørmanualen må alltid være tilgjengelig.
- PL** Proszę uważnie przeczytać instrukcję obsługi przed uruchomieniem urządzenia i stosować się do przepisów bezpieczeństwa. Instrukcje obsługi muszą być zawsze dostępne.
- RUS** Пожалуйста, прочитайте инструкцию по эксплуатации перед установкой аппарата, соблюдайте технику безопасности. Инструкция по эксплуатации должна находиться в доступном для пользователя месте.
- H** A gép üzembe helyezése előtt figyelmesen olvassa el a kezelési utasítást és tartsa be a biztonsági előírásokat. Kezelési utasításnak mindig elérhetőnek kell lennie.
- TR** Lütfen makineyi çalıştırmadan önce bu kullanma talimatlarını dikkatli bir şekilde okuyunuz ve belirtilen güvenlik önlemlerine uyunuz. Kullanma Talimatları her zaman kullanıma hazır olmalıdır.
- DK** Før installation af maskinen bedes De venligst læse brugervejledningen brugervejledningen og være opmærksom på sikkerhedsanvisningerne. Brugervejledningen skal altid være tilgængelig.
- CZ** Prosím přečtěte si instrukce k obsluze a dodržujte bezpečnostní upozornění. Návod k obsluze musí být vždy dostupný.
- P** Por favor leiam o manual de instruções antes de colocar a máquina em operação e vejam as precauções de segurança. As instruções de operação deverão estar sempre disponíveis.
- GR** ΠΑΡΑΚΑΛΩ ΔΙΑΒΑΣΤΕ ΤΙΣ ΟΔΗΓΙΕΣ ΧΡΗΣΕΩΣ ΚΑΙ ΤΙΣ ΠΡΟΦΥΛΑΞΙΕΣ ΑΣΦΑΛΕΙΑΣ ΠΡΙΝ ΒΑΛΕΤΕ ΤΟ ΜΗΧΑΝΗΜΑ ΣΕ ΛΕΙΤΟΥΡΓΙΑ. ΟΙ ΟΔΗΓΙΕΣ ΧΡΗΣΗΣ ΠΡΕΠΕΙ ΝΑ ΕΙΝΑΙ ΠΑΝΤΑ ΔΙΑΘΕΣΙΜΕΣ.
- CHI** 使用機器前，請閱讀此操作指引，並留意安全守則
操作手冊必須是經常可用的。
- UAE** الامان والوقاية تعليمات ملاحظة نرجوا كما الماكينة بتشغيل قبل التشغيل تعليمات قراءة نرجوا
لا بد من وجود تعليمات التشغيل دائما

- Sicherheitshinweise • Safety precautions •
- Consignes de sécurité • Veiligheidsvoorschriften •
- Misure di Sicurezza • Normas de Seguridad •
- Säkerhetsföreskrifter • Turvallisuusohjeita • Sikkerhetsforskriftene •
- Środki bezpieczeństwa • Меры предосторожности •

IDEAL



- D** Keine Bedienung durch Kinder!
GB Children must not operate the machine!
F Pas d'utilisation par un enfant!
NL Geen bediening door kinderen!
I Non lasciare utilizzare il tagliacarte a bambini!
E No dejar que la utilicen los niños!
S Installera maskinen utom räckhåll för barn!
FIN Asentakaa laite lasten ulottumattomiin !
N Installer maskinen utenfor rekkevidde for barn!
PL Dzieciom nie wolno obsługiwać urządzenia !
RUS Не допускайте детей к пользованию аппаратом!
H Gyerekek a gépet nem kezelhetik
TR Makinayı Çocuklar Kullanmamalıdır.
DK Må kun betjenes af voksne
CZ Stroj nesmí být obsluhován dětmi
P As crianças não devem trabalhar com a máquina!
GR ΑΠΑΓΟΡΕΥΕΤΑΙ Η ΧΡΗΣΗ ΑΠΟ ΠΑΙΔΙΑ.
CHI 勿让儿童使用机器!
UAE يجب علي الأطفال عدم تشغيل الماكينة.



- D** Nicht unter das Messer fassen!
GB Do not reach beneath the blade!
F Ne pas passer les mains sous la lame!
NL Niet met de handen onder het mes komen!
I Non toccare la lama nella parte inferiore!
E ¡No tocar debajo de la cuchilla!
S Sträck inte in handen under kniven!
FIN Älä laita kättäsi terän alle !
N Plasser aldri hender ol. under kniven!
PL Nie wkładac rak pod noże!
RUS Избегайте попадания рук под лезвие!
H Ne nyúljon a kés alá!
TR Elinizi bıçağın altına sokmayınız!
DK Stik ikke hænderne ind under knivbladet!
CZ Nesahejte pod ostří nože!
P Não tocar na parte inferior da faca!
GR ΜΗΝ ΑΓΓΙΖΕΤΕ ΤΟ ΚΑΤΩ ΜΕΡΟΣ ΤΗΣ ΛΕΠΙΔΑΣ!
CHI 请勿接触刀具的下方。
UAE لا تصل تحت السكين

- Sicherheitshinweise • Safety precautions •
- Consignes de sécurité • Veiligheidsvoorschriften •
- Misura di Sicurezza • Normas de Seguridad •
- Säkerhetsföreskrifter • Turvallisuusohjeita • Sikkerhetsforskriftene •
- Środki bezpieczeństwa • Меры предосторожности •

IDEAL 4810-95/EP • IDEAL 4850-95/EP • IDEAL 5221-95EP • IDEAL 6550-95EP



- D** Messer nie lose liegen lassen!
Messer nur mit Messerwechsellvorrichtung oder im
Messertransportkasten befördern!
(siehe Seite 31 und 33).
⚠️ Warnung! Verletzungsgefahr!
- GB** Never leave the blade unattended!
Do not extract or transport the blade without protection!
(See page 31 and 33).
⚠️ Danger! Risk of injury!
- F** Ne jamais laisser la lame sans protections !
Elle ne doit être démontée qu'à l' aide du dispositif de
changement de lame (cf. page 31 et 33), ou transportée dans
son étui en bois !
⚠️ Danger! Risques de coupures !
- NL** Laat nooit de messen alleen achter.
Transporteer de messen niet zonder de houten bescherming
(zie pagina 31 en 33).
⚠️ Waarschuwing! Opgelet voor ongevallen!
- I** Non lasciare mai la lama incustodita. Non rimuovere o
trasportare la lama senza protezione. (Vedi pagina 31 e 33).
⚠️ Attenzione! Rischio di infortunio!
- E** ¡No quitar la cuchilla sin prestar atención. No desmontar no
transportar la cuchilla sin protección! (vérase pág. 31 y 33)
⚠️ ¡Advertencia! ¡Peligro de hacerse daño!
- S** Lämna aldrig maskinen obemannad. Ta inte ur eller
transportera kniven utan skydd. (se sid 31 och 33).
⚠️ Skaderisk!
- FIN** Käsittele terää aina varoen. Älä siirrä tai kuljeta
terää ilman suojaa ! (katso sivu 31 ja 33)
⚠️ Loukkaantumisen vaara !
- N** La aldri kniven ligge ubeskyttet. Ta aldri ut kniven eller
transporter den uten beskyttelse (Se side 31 og 33)
⚠️ FARE ! Muligheter for skade !
- PL** Nigdy nie pozostawiac noży bez nadzoru.
Nie wyciągac lub transportowac noży bez osłon!
(zobacz strona 31 i 33).
⚠️ Ryzyko skaleczenia sie!
- RUS** Не оставляйте открытое лезвие без присмотра! Не
пытаться извлечь или транспортировать лезвие без
специальных мер предосторожности!
(См. страницы 31 и 33)
**⚠️ Соблюдайте выше перечисленные правила
для избежания травм!**
- H** Soha ne hagyja a kést őrizetlenül!
Ne vegye ki vagy ne szállítsa a kést védőtok nélkül!
(Lásd 31. és 33. oldal)
⚠️ Veszély! Sérülésveszély!
- TR** Bıçağı hiçbir zaman gözetimsiz bırakmayınız!
Bıçağı muhafazasız olarak yerinden çıkartmayınız veya
taşımayınız! (Sayfa 31 ve 33'e bakınız)
⚠️ Dikkat! Yaralanma riski!

- Sicherheitshinweise • Safety precautions •
- Consignes de sécurité • Veiligheidsvoorschriften •
- Misure di Sicurezza • Normas de Seguridad •
- Säkerhetsföreskrifter • Turvallisuusohjeita • Sikkerhedsforskriftene •
- Środki bezpieczeństwa • Меры предосторожности •

IDEAL



- DK** Knivbladet må aldrig efterlades uden opsyn.
Forsøg ikke at afmontere eller transportere knivbladet uden beskyttelse! (Se side 31 og 33)
⚠ FARE! Risiko for legemlig beskadigelse.
- CZ** Nikdy nenechávejte nůž bez krytu.
Nikdy nevyjímejte nebo nepřepravujte nůž bez ochranného krytu (viz. strany 31 a 33)
⚠ Nebezpečí! Riskujete zranění
- P** Deixar a faca sempre em local seguro!
Não retirar ou transportar a faca sem protecção!
(Ver pág. 31 e 33)
⚠ Perigo! Risco de dano!
- GR** ΜΗΝ ΑΦΗΝΕΤΕ ΤΗΝ ΛΕΠΙΔΑ ΑΝΕΠΙΤΗΡΗΤΗ!
ΜΗΝ ΑΛΛΑΖΕΤΕ Ή ΜΕΤΑΦΕΡΕΤΕ ΤΗΝ ΛΕΠΙΔΑ ΧΩΡΙΣ
ΠΡΟΦΥΛΑΞΗ (Δείτε σχετικά στις σελίδες 31 & 33)
⚠ ΠΡΟΣΟΧΗ! ΚΙΝΔΥΝΟΣ ΤΡΑΥΜΑΤΙΣΜΟΥ!
- CHI** 在没人留意的情况下，请勿离开刀具。
在没有保护的情况下，请勿取出或运送刀具！（参阅第 31 和 33 页）。
⚠ 危险！可引致受伤！
- UAE** لا تترك السكين بدون اهتمام
لا تخرج أو تنقل السكين بدون حماية (انظر صفحة 31 و 33)
⚠ خطر! التعرض للآذى

- Sicherheitshinweise • Safety precautions •
- Consignes de sécurité • Veiligheidsvoorschriften •
- Misure di Sicurezza • Normas de Seguridad •
- Säkerhetsföreskrifter • Turvallisuusohjeita • Sikkerhetsforskriftene •
- Środki bezpieczeństwa • Меры предосторожности •

IDEAL 4810-95/EP • IDEAL 4850-95/EP • IDEAL 5221-95EP • IDEAL 6550-95EP



- D** Keine harte und splitternde Materialien schneiden!
GB Do not cut hard materials or materials which may splinter!
F La coupe de matériaux trop durs ou risquant des projections est interdite !
NL Snij geen harde materialen of materiaal dat kan splinteren!
I Utilizzare il tagliacarte esclusivamente per il taglio di risme di carta o materiali analoghi!
E ¡No cortar materiales duros o materiales que puedan astillarse!
S Försör inte hårt material eller material som kan splittras!
FIN Asentakaa laite lasten ulottumattomiin !
N Ikke kutt hardt metall eller materiale som kan splintre !
PL Nie ciac twardych materiałów lub materiałów, które mogą ulec odprysnięciu!
RUS Данный резак не предназначен для резки твердых материалов или материалов, которые могут расщепляться!
H Ne vágjon kemény vagy olyan anyagot, amely repedhet!
TR Sert veya parçalanabilecek malzemeleri kesmeyiniz!
DK Der må ikke skæres i hårde materialer eller i materialer, der kan splintre!
CZ Neřežte tvrdý materiál, při kterém mohou ustřelovat ostré úlomky!
P Não cortar materiais duros ou materiais que possam lascar!
GR ΜΗΝ ΚΟΒΕΤΕ ΣΚΛΗΡΑ ΥΛΙΚΑ Ή ΥΛΙΚΑ ΠΟΥ ΘΡΥΜΜΑΤΙΖΟΝΤΑΙ!
CHI 请勿切割坚硬或可裂成碎片物料。
UAE لا تقطع الأشياء الصلبة أو الأشياء التي يتطاير منها شظايا!

• Safety precautions •

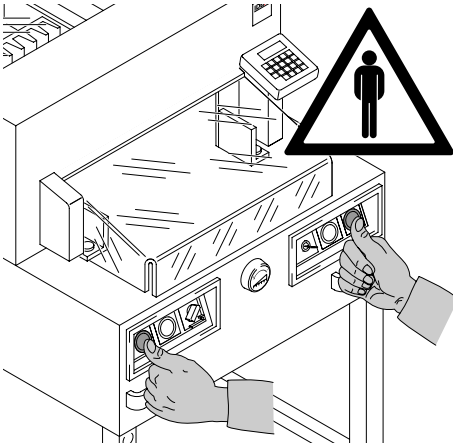

The machine is designed for cutting stacks of paper to a specified size.
This machine is constructed for "one-man operation" only!

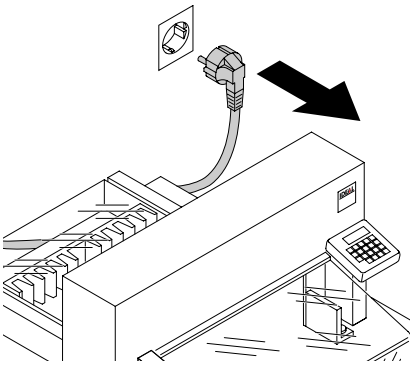

Disconnect from the mains before starting any service work or before removing the panels!

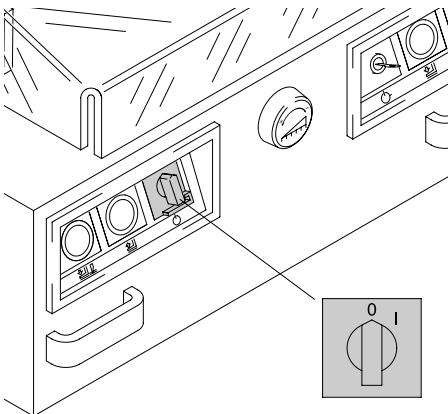

Replacement of blade and cutting stick may be performed only when the main switch is switched off!

IDEAL 4810-95/EP • IDEAL 4850-95/EP • IDEAL 5221-95EP • IDEAL 6550-95EP

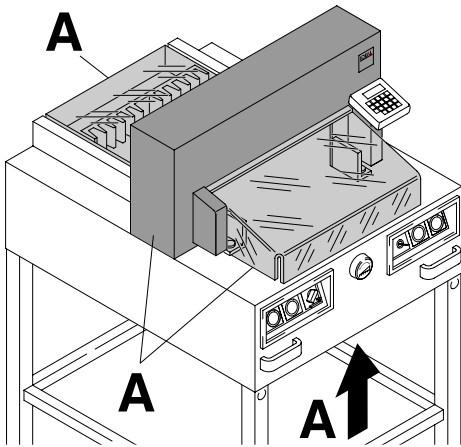

All components which could endanger the operator are covered by a guard!

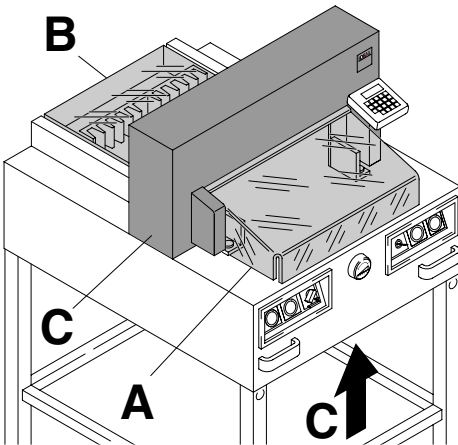

Operating the machine without safety device is forbidden!
(Front safety guard (A), rear screwed safety guard (B) and panel (C)).

The dangerous cutting movement is safeguarded by a movable guard (A) and a safety two-handed control system! (B)

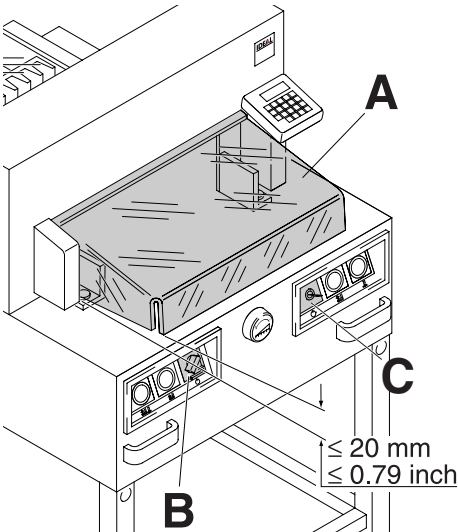
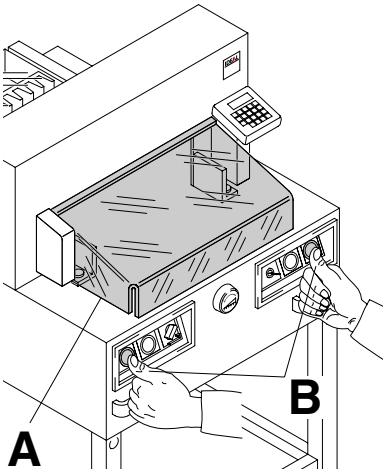

Before working with the machine and after every blade replacement the automatic cut-off function of safety guard (A), (correct if distance between cover and table is $< 20 \text{ mm}$) main switch (B) and control panel (C) must be checked.

IDEAL 4810-95/EP • IDEAL 4850-95/EP • IDEAL 5221-95EP • IDEAL 6550-95EP

Protect mains cable against heat, oil and sharp edges!

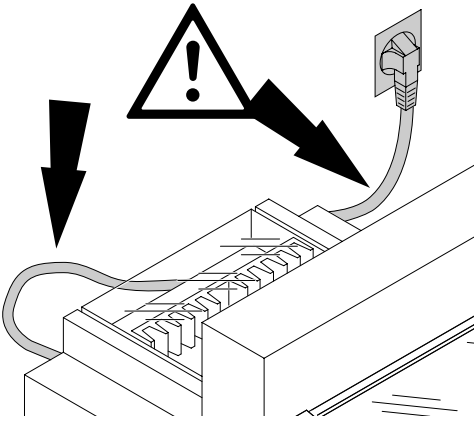

230 V / 10A min
115 V / 15A min

Connect the power cord to a single phase socket.

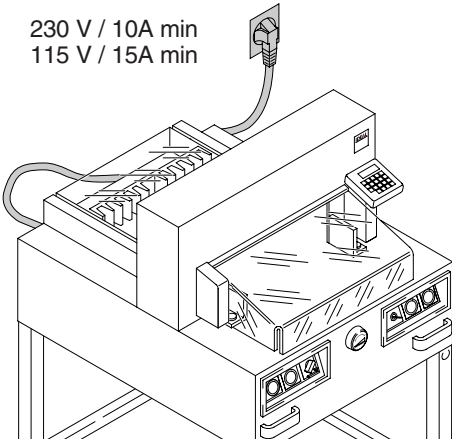

Ensure free access to mains!

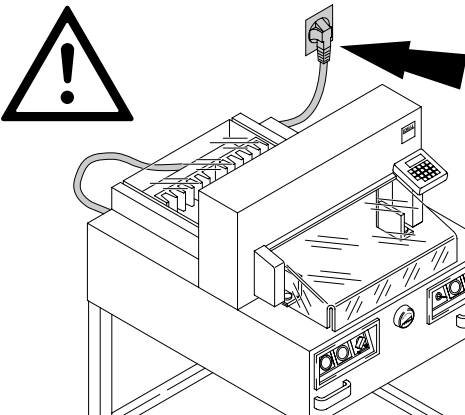

• Safety precautions •

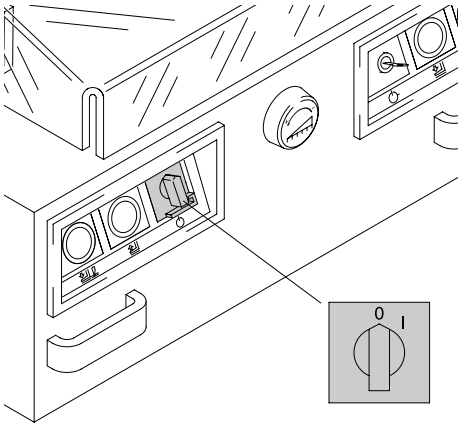

When not in use for a longer period switch off.
(Main switch to "0").

IDEAL 4810-95/EP • IDEAL 4850-95/EP • IDEAL 5221-95EP • IDEAL 6550-95EP

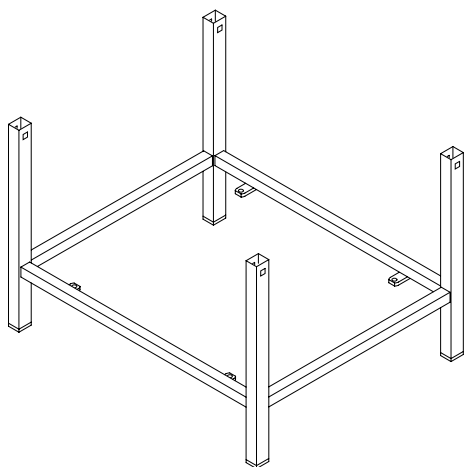

**Only IDEAL 4810/EP IDEAL 4850/EP
IDEAL 6550EP**

Remove the stand from the wooden pallet.

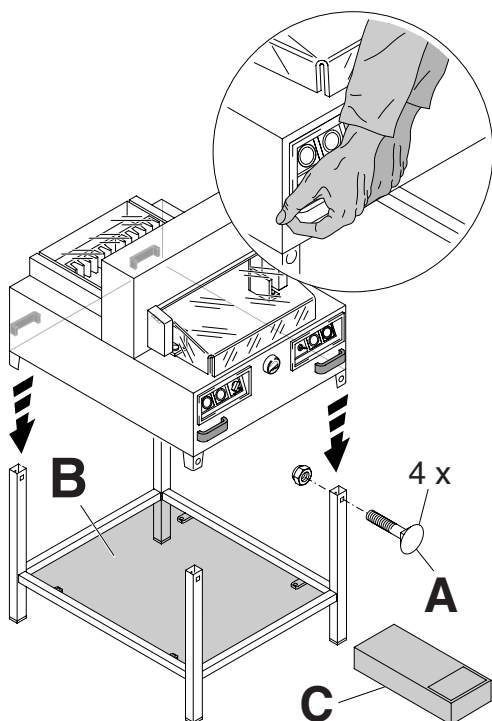

**Only IDEAL 4810/EP IDEAL 4850/EP
IDEAL 6550EP**

4 strong people are required to lift the machine from the pallet and place it on the stand. Secure with 4 screws (A). Put the shelf (B) on the stand. (Parts and tools are in the tool set (C)).

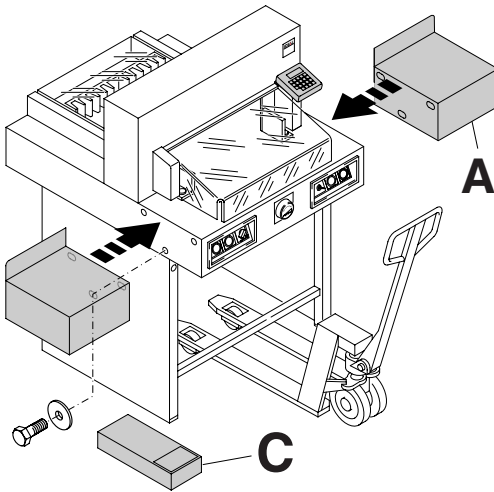

IDEAL 5221-95EP

The machine is delivered ready for operation.

4 strong people are required to lift the machine from the pallet.

Side tables, left and right, (A) are available as accessories.

Attach the side tables to the front table so that the upper surface is level.

(Screws and nuts are in a plastic bag in the tool set (C).

The front and rear wooden panels must be removed for **in-house transport** on a pallet truck.

For transport through narrow doors:

- Remove side tables
- Remove the machine from its base (4 screws)
- Tilt the machine on its side
- Mount the machine to its base
- Screw on all side panels

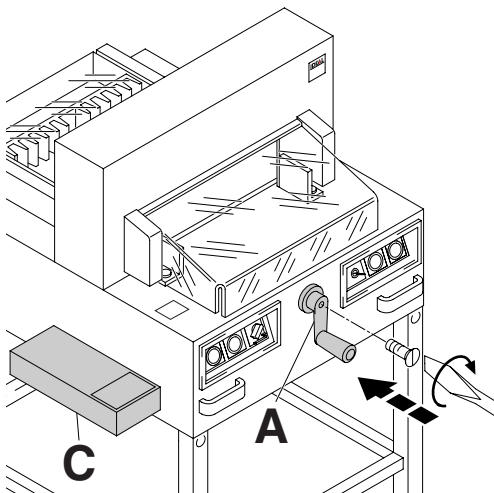

Only IDEAL 4810-95, 4850-95, 6550-95

Tighten the backgauge crank (A). Parts and tools are in the tool set (C).

IDEAL 4810-95/EP • IDEAL 4850-95/EP • IDEAL 5221-95EP • IDEAL 6550-95EP

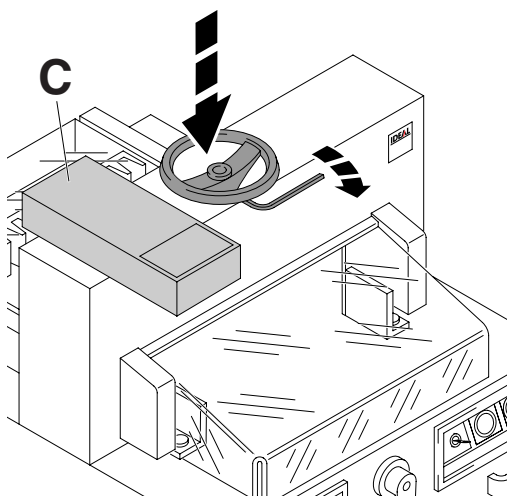

Only IDEAL 4810-95/EP

Attach the enclosed hand-wheel for clamping.
Parts and tools are in the tool set (C).

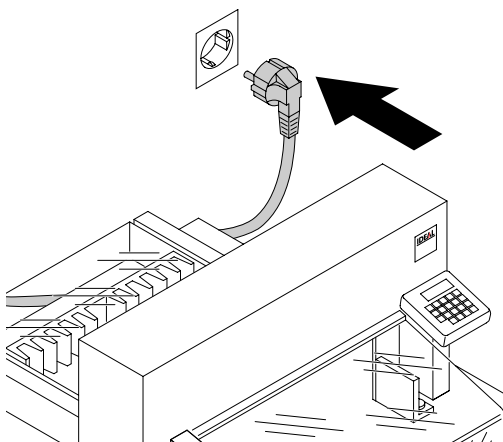

Plug into socket.

The machine must be connected directly to the socket.

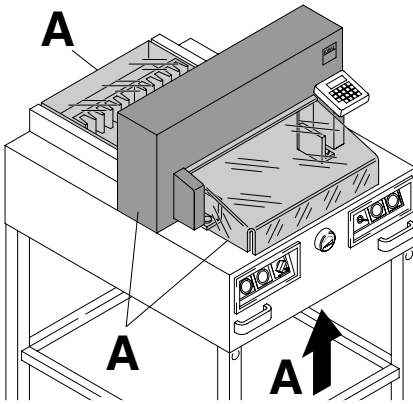

It is forbidden to operate the machine if the operating and safety instructions have not been understood. Please check the safety devices are functioning and complete before use.

- All covers have to be mounted (A).
- The release for cutting is allowed only if the cover is closed and the two-hand safety device is operated at the same time (B)
- If the front cover closes by itself the gas spring (X) needs replacing.

We recommend you keep a record of your test results.

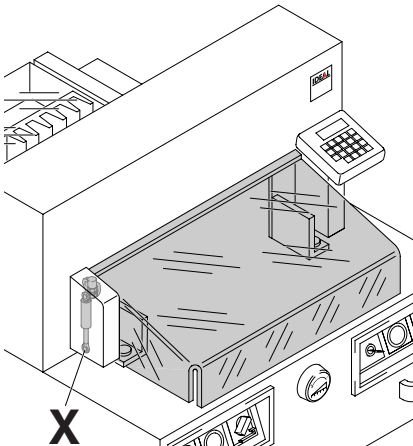
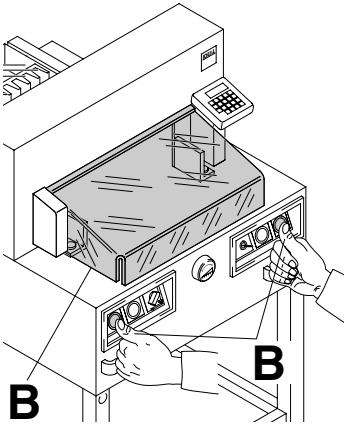

IDEAL 4810-95/EP • IDEAL 4850-95/EP • IDEAL 5221-95EP • IDEAL 6550-95EP

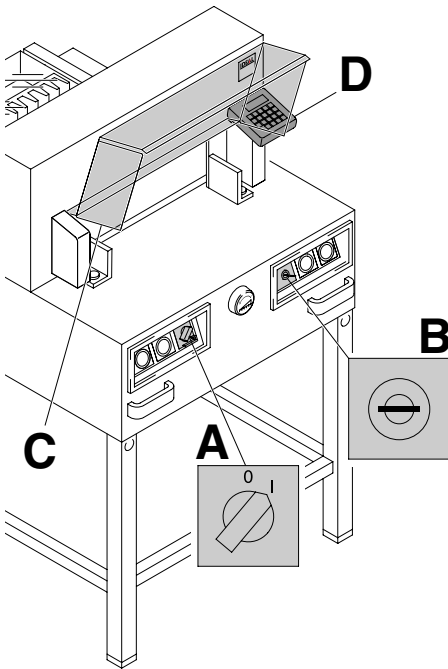

Position the main switch to "I" (A). Insert the key for the control system and move it to the right (B). Open the safety guard (C). The machine is now ready for use.

Only IDEAL 4810-95EP, IDEAL 4850-95EP, IDEAL 5221-95EP, IDEAL 6550-95EP

Press  button (D).

Machine will automatically go to the start position.

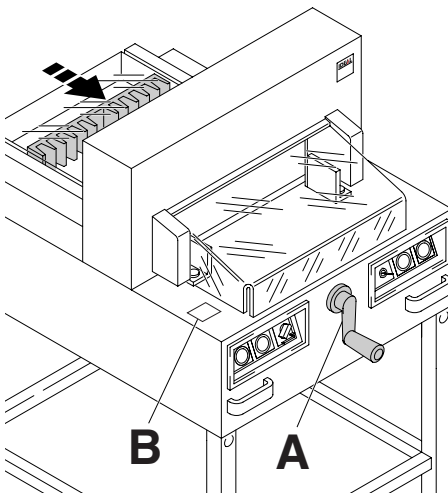

IDEAL 4810-95, IDEAL 4850-95,

The measurement is set with the backgauge crank (A). Proceed to position → generally from the rear.

The measurement is shown on the scale (B) just below the indicator and can be read in mm/cm or inches.

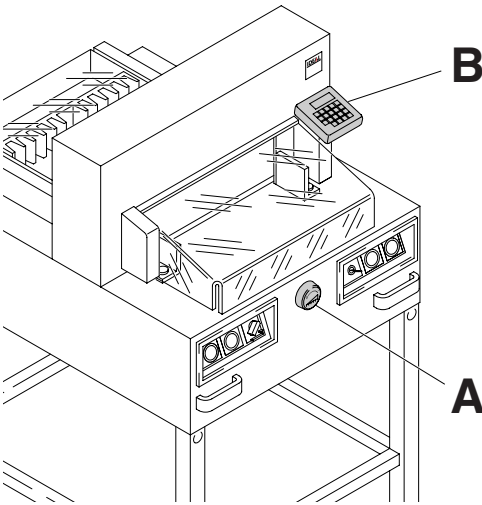

**IDEAL 4810-95EP, IDEAL 4850-95EP,
IDEAL 5221-95EP, IDEAL 6550-95EP**

The measurement is set either with the hand-wheel (A) or by programming (B) the cutting measurements. Measurement is shown on the display in inches or cm (B).

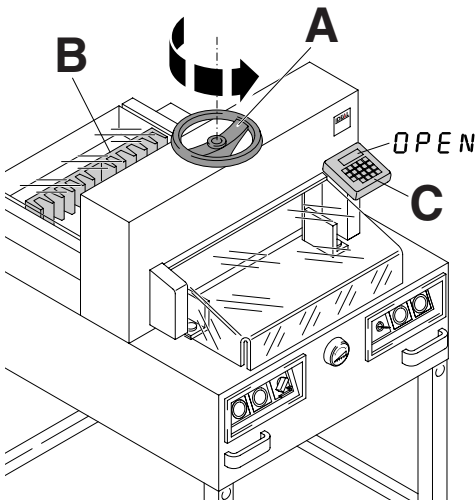

Only IDEAL 4810-95EP

If display shows "OPEN " the clamp must be completely opened.

Turn the hand-wheel for clamping (A) completely to the left until the backgauge (B) is activated.

IDEAL 4810-95/EP • IDEAL 4850-95/EP • IDEAL 5221-95EP • IDEAL 6550-95EP

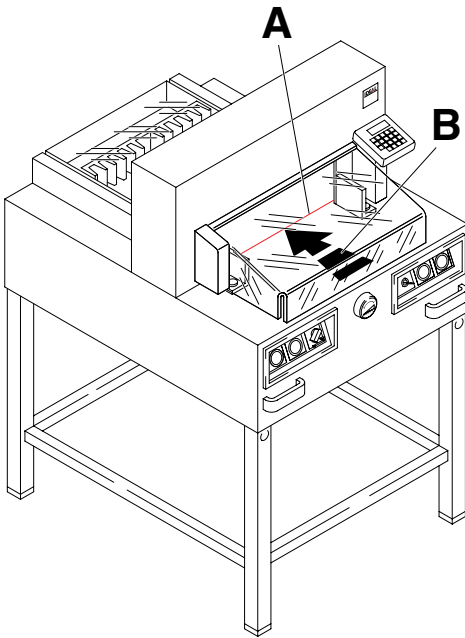

Optical cutting line (A) that indicates the exact position of the cut. Blade cuts on the front edge (B) of the light beam. (Only use when no exact cut is required).

IDEAL 4810-95 has no cutting line indicator.

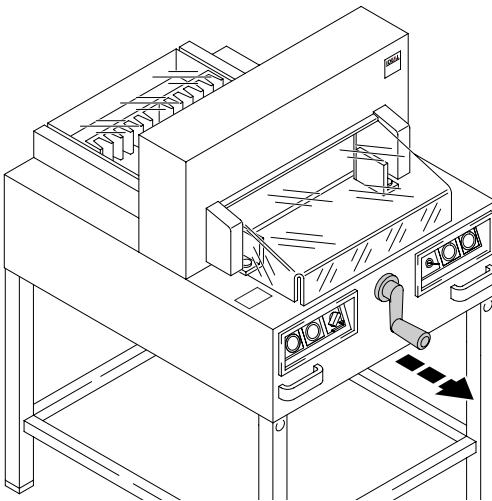

Only IDEAL 4810-95, IDEAL4850-95.

Pull out the handle to avoid the measurement being wrongly adjusted.

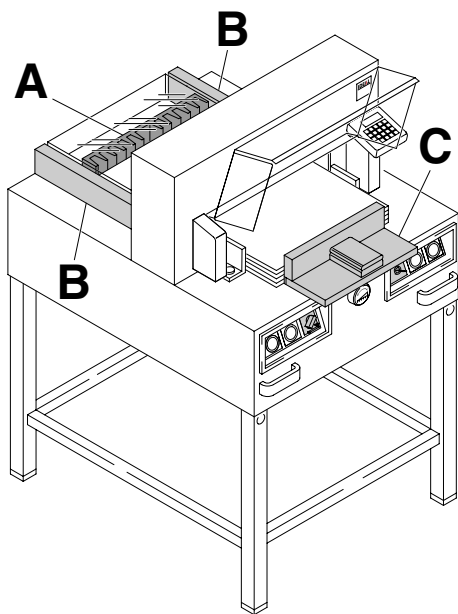

Position the paper on the backgauge (A) and side lays left or right (B). To move paper stacks, please use the paper knock-up block (C) provided. (Run backgauge to the front for turning the paper stack).

IDEAL 4810-95/EP • IDEAL 4850-95/EP • IDEAL 5221-95EP • IDEAL 6550-95EP

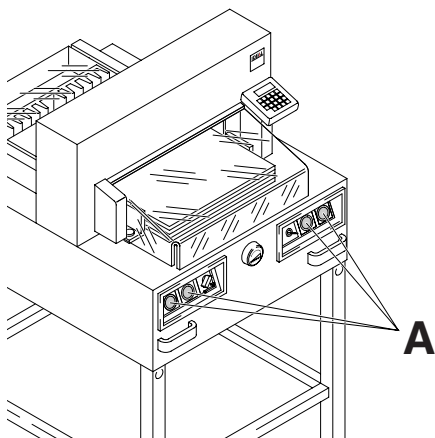

**IDEAL 4850-95/EP, IDEAL 5221-95EP
IDEAL 6550-95/EP**

The clamp moves automatically when cutting is activated.

The paper can also be pressed in advance. Clamping and cutting is activated by pressing button (A) on the front table.



Pre-clamping



Clamp returns



Cutting sequence with automatic clamping

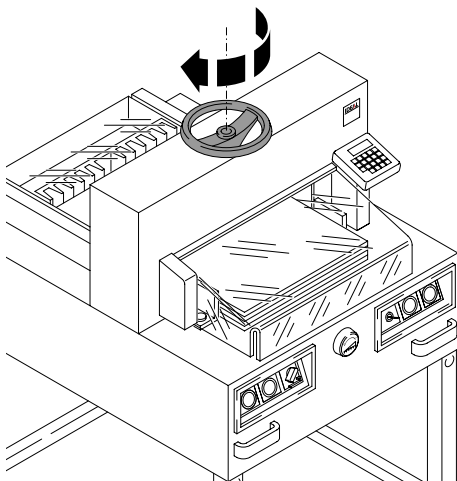

Only 4810-95

Clamping is released by the hand-wheel. Before every cut lower the clamp by turning the hand-wheel to the right and tighten with a light twist. The cut is activated by pressing the two buttons exactly at the same time.



Close the safety guard.

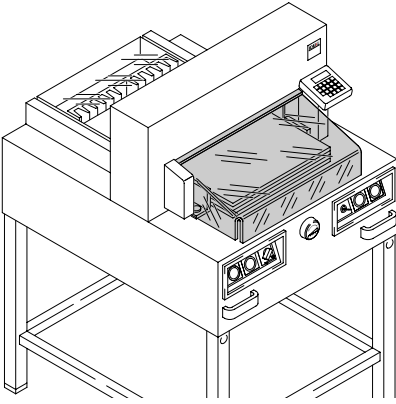

Cutting activation:

Press both buttons of the two-handed control system activation (A) simultaneously and then pressed until the paper is completely cut.

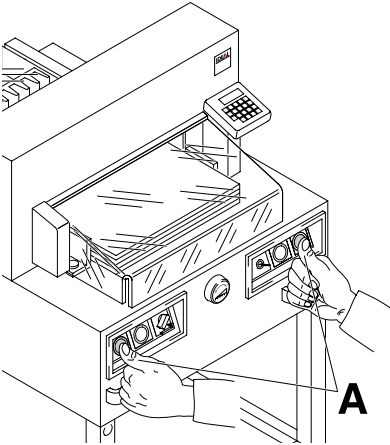

To interrupt or stop cutting:

To interrupt or stop cutting, release both buttons (A) of the two-hand control.

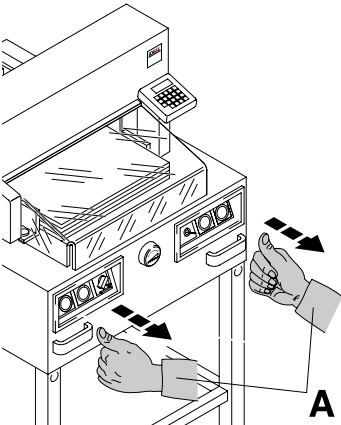

IDEAL 4810-95/EP • IDEAL 4850-95/EP • IDEAL 5221-95EP • IDEAL 6550-95EP

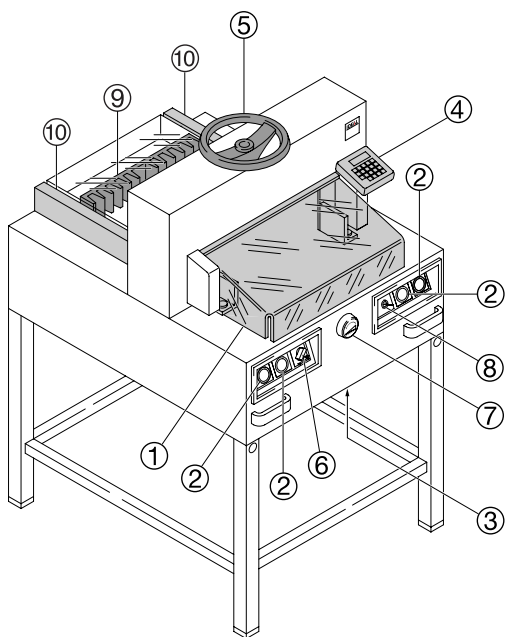

Operating elements

- ① - Front safety guard
- ② - Safety two-handed control system
Pre-clamping and cutting
- ③ - Overload switch
(blade drive/clamp drive/
backgauge drive)
- ④ - Backgauge control (EP)
- ⑤ - Paper clamp
(only IDEAL 4810-95/EP)
- ⑥ - Main switch
- ⑦ - Hand-wheel (EP) or crank handle
for backgauge setting
- ⑧ - Key switch
- ⑨ - Backgauge
- ⑩ - Side lay left and right
- ⑪ - Display cutting size (EP, cm or inch)

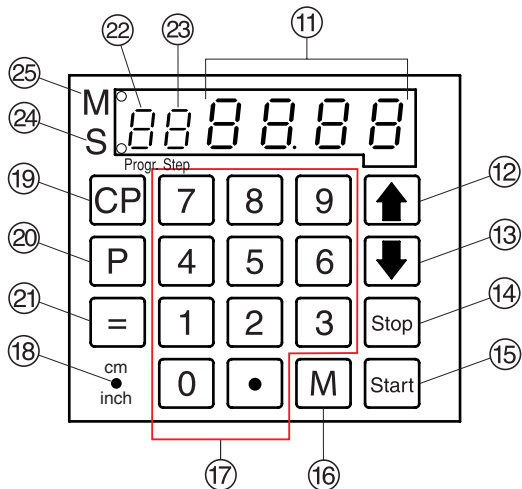

- ⑫ - Select program step up
- ⑬ - Select program step down
- ⑭ - Stop and delete input
- ⑮ - Start
- ⑯ - Memory multiple cut
- ⑰ - Keypad
- ⑱ - Changeover cm - inch
- ⑲ - Clear program
- ⑳ - Select program
- ㉑ - Enter
- ㉒ - Program number
- ㉓ - Program step
- ㉔ - Specified dimensions
- ㉕ - Display multiple cut

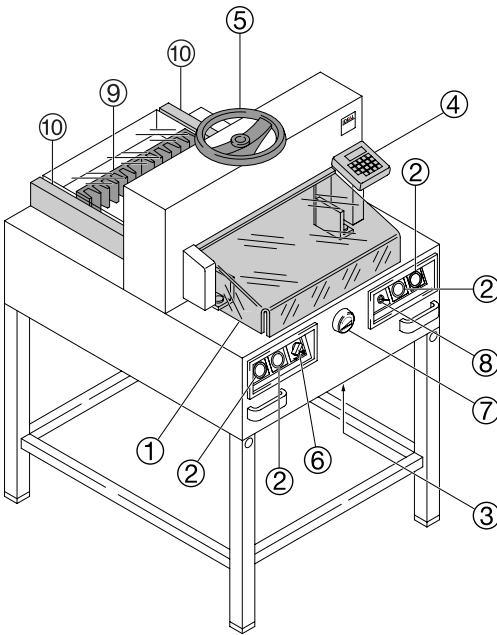

**IDEAL 4810-95EP, IDEAL 4850-95EP,
IDEAL 5221-95EP, IDEAL 6550-95EP**
Start machine

- Main switch ⑥ to position "I", insert the key ⑧ for the control panel and turn it to the right.
- Open the front safety guard ①
- Press **Start** button ⑮ → backgauge ⑨ moves to the rear and searches for the reference position, wait until a measurement is shown in the display ④.
 IDEAL 4810-95/EP = 45 cm, 17,72 inches
 IDEAL 4850-95/EP = 45 cm, 17,72 inches
 IDEAL 5221-95EP = 52 cm, 20,47 inches
 IDEAL 6550-95/EP = 61 cm, 24,02 inches

⚠ Warning!

Before storing or cutting a measurement please check if the correct measurement scale (cm or inch) see above is stored. For information on how to store see picture below left.

Cutting to specified dimensions

- Enter dimension on the numerical key pad ⑰ → LED "S" ⑳ appears.
(If a wrong dimension is entered this can be corrected by pressing the **Stop** button).
- Press **Start** button → dimension is approached, → LED "S" disappears.
- Dimensions below 9 cm can only be approached with the **Start** button pressed and held. (When the **Start** button ⑮ is released, the backgauge ⑨ moves to a measurement of 9 cm → measurement 9 cm blinks, keep the **Start** button pressed, backgauge ⑨ moves to e.g. 7 cm.
- Insert paper and move by means of the stacking angle to the backgauge ⑨ and side lay on the left ⑩.
- **Only IDEAL 4810-95/EP**
Turn the hand-wheel ⑤ for paper clamping to the right and tighten with a short twist.
- Close the front safety guard ①.
- Release the cut.

Cut according to markings

- Adjust the backgauge with the hand-wheel or crank handle ⑦ to the back.
- Insert paper and move by means of the stacking angle to the backgauge ⑨ and side lay on the left ⑩.
- Turn the hand-wheel or crank handle ⑦ to the right until the marking on the paper to be cut is below the cutting line indicator.

IDEAL 4810-95 has no cutting line indicator.

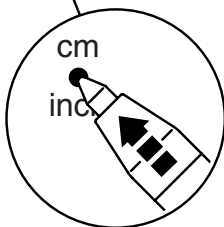
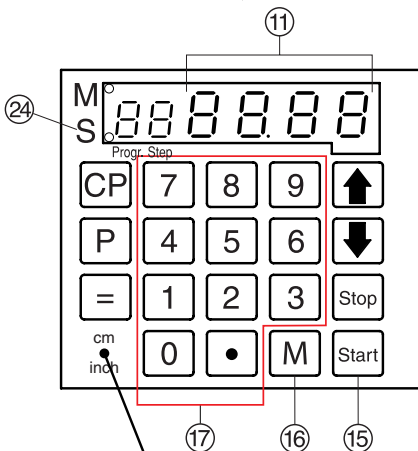

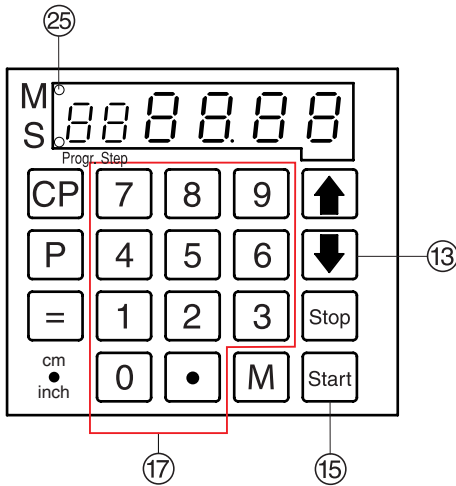

Only EP machines.

- The further the hand-wheel ⑦ is turned to the right, the quicker the backgauge moves. If the hand-wheel is turned to the left the backgauge will return quicker.

Only IDEAL4810-95/EP

- Turn the hand-wheel for paper clamping ⑤ to the right and tighten with a short twist.
- Close the front safety guard ①.
- Release the cut.

Eject function

If button ⑬ is pressed instead of button ⑮, after inserting the measurement, the backgauge will advance forwards to measurement 9 cm/0,36 inch (standard setting of the machine) so that paper can be removed. Finally the backgauge moves to the last setting.

Adjust the eject-dimension

- Press , Press press → *EJ* on display.
- Insert the desired dimension.
- Store dimension.

Multiple cut

- Enter the multiple cut size on the display ⑰.
- Advance to the measurement with the button.
- Push the paper to the backgauge ⑨.
- Press button → the red LED "M" ⑳ light will be on.
- Enter the multiple cut size.
- After cutting has been activated press button. Every time the button is pressed, the backgauge will advance by the multiple cut size.
- Pressing the button ⑭ shows the actual size.

Exiting program-mode

- Press button → LED "M" ⑳ is cleared on the display.

Cutting activation

⚠ Warning!

- Run backgauge to the front for turning the paper stack.
- Do not interrupt the upward movement of the blade by performing switching procedures.
- Release blade only when LED "S" has gone out.
- Close the front safety guard ①.
- Blade must always be at the top and be covered by the clamp. Do not touch the blade
⚠ risk of injury! (see safety information on page 36).

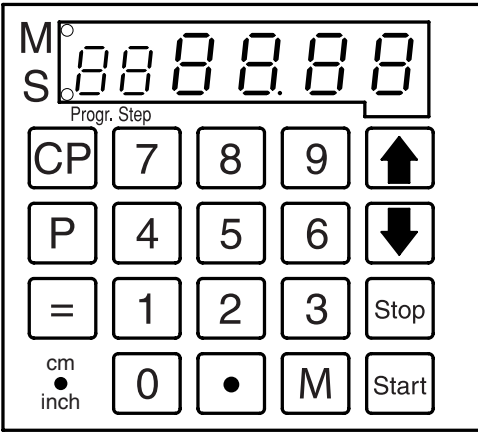

Programming

Only IDEAL 4810_95EP, IDEAL 4850-95EP, IDEAL 5221-95EP, IDEAL 6550-95EP

This control system enables you to store 9 programs with 9 programmable steps. One step represents one measurement. After entering the program numbers you are able to change between several program steps with the button \downarrow and \uparrow .

First figure on display = program number.

Second figure = program step.

Dimensions below 9 cm can only be approached with the Start button held pressed. "UL" on the display \rightarrow the entered dimension is too low.

"OL" on the display \rightarrow the entered dimension is too high.

Each program step corresponds to one dimension. The indicated program step can be overwritten at any time. These programs remain stored when the machine is off. Should you change to another dimension unit all programmed measurements are converted into the new unit (cm or inch).

Entering a program

- Press P \rightarrow PR appears on the display.
- $\text{1} \dots \text{9}$ Enter program number 1...9. (First figure on display = program number).
- Enter dimension, or move the backgauge to the desired measurement with the hand-wheel.
- = Store the dimension \rightarrow next program step appears. If the hand-wheel $\text{\textcircled{7}}$ is used to approach the cutting position press button \uparrow next program step appears.
- Enter the next dimension. (Should an ejection be desired before this cut push the = button and \downarrow button simultaneously).
- Should the entered program be required immediately \rightarrow press Start (program is closed). Press Start again (backgauge moves to the dimension of the first program).
Or:
- $\text{P} + \text{Stop}$ Escape the program mode.

Eject function program

- Set the measurement \rightarrow push = button and \downarrow simultaneously. EJ appears shortly on the display. The backgauge will advance and eject the paper and finally return to the position shown on the display.

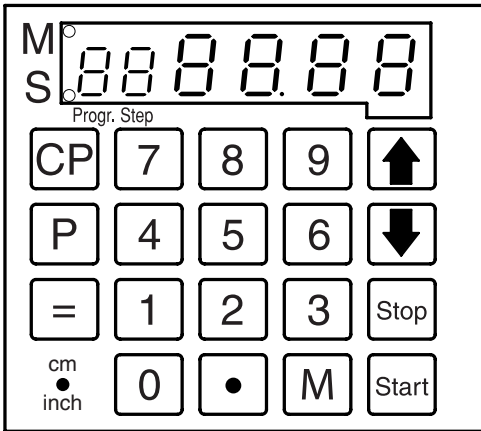

Programming of multiple cut dimension

- **[P]** Press → *PR* appears on the display.
- **[1] ... [9]** Enter program number 1 ... 9.
First figure on display = program number.
Second figure = program step.
Enter the cut size on the display **[7]**.
- **[=]** Store the dimension.
- **[1] ... [9]** Enter multiple cut size.
→ Press **[M]** button *n!* and multiple cut size appears on the display.
Press **[M]** button again *n²* and second multiple cut size appears etc.
- **[=]** Store the dimension.
- **[P] + [Stop]** Escape the program mode.
Maximum nine multiple cuts can be entered.
Entering the tenth multiple cut will delete the multiple cut and the display will show the actual program step.

Deleting a dimension when programming

Press **[Stop]** and overwrite the dimension.

Cancel a program

- **[P]** press → *PR* appears on the display.
- **[1] ... [9]** Enter program number 1 ... 9.
- Press button **[CP]** twice.
Each program has to be cancelled separately.
Only single program steps can be overwritten.

Deleting the last program step

- Enter **[0]**.
- Press **[=]**.
- **[P] + [Stop]** Escape the program mode.

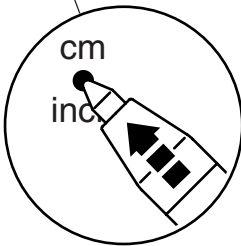
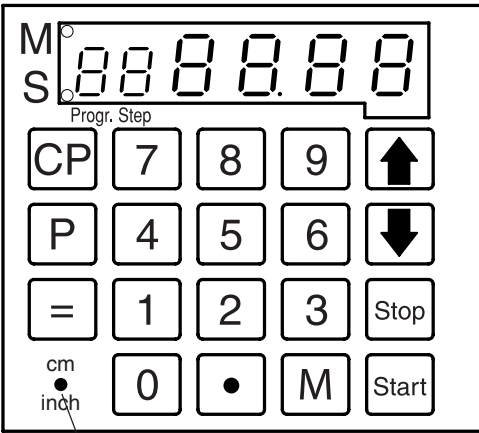

Working with programs

- Press **[P]** → *PR* appears on the display
- **[1] ... [9]** Enter program number 1 ... 9
- With the button **[↓]** and **[↑]** you are able to change between several program steps.
- With **[Start]** the backgauge moves to the indicated dimension.
- With **[Stop]** the backgauge stops.

General

LED "S" blinks → the basic position will appear.
 LED "S" is off → the actual dimension appears.
 In the program mode the ejection of paper **[↓]** is not possible. The ejection of paper has to be programmed.

After each cut press the button **[Start]** the backgauge moves to the next dimension.

Escape the program mode

- Press **[P]** → *PR* appears on the display.
- Press **[Stop]** → escape the program mode.

Program buttons **[↑]** and **[↓]** programs

- Button **[↑]** = backgauge position rear
- Button **[↓]** = backgauge position front
- Press **[P]** and simultaneously **[↑]** (*P_r* appears on the display) or
- Press **[P]** and simultaneously **[↓]** (*P_d* appears on the display)
- Enter the desired dimension (For example: 29,7 cm x 42 cm can be entered for DIN A3)
- **[=]** Store dimension.

Display in cm or inch

- Press **$\frac{cm}{inch}$** → display changes between cm and inch (see picture left).
- Measurements (in cm or inches) for the rear reference point of the backgauge are shown on the top of page 23.

IDEAL 4810-95/EP • IDEAL 4850-95/EP • IDEAL 5221-95EP • IDEAL 6550-95EP

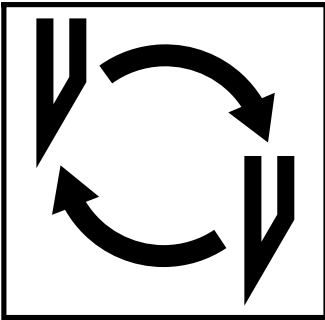

If the cutting quality decreases:

- Check the cutting depth (see page 36).
- Check the cutting stick (see page 32).
- Replace or grind the blade (see page 28 - 36).

The blade cannot be ground if the blade height is less than 83 mm/3,29 inches.

A new blade must be used.

The blade may only be ground by a qualified supplier or from the manufacturer Krug & Priester, D-72336 Balingen.

⚠ Danger! Risk of injury!

The blade is extremely sharp. Do not extract or transport the blade without protection. Changing the blade may only be performed by trained staff.

• Blade and cutting stick replacement •

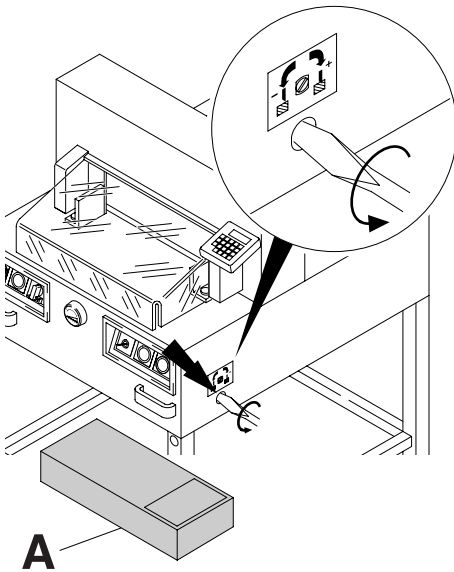

Turn the blade depth adjustment screw to the left until it stops. (Screwdriver found in tool set (A)).

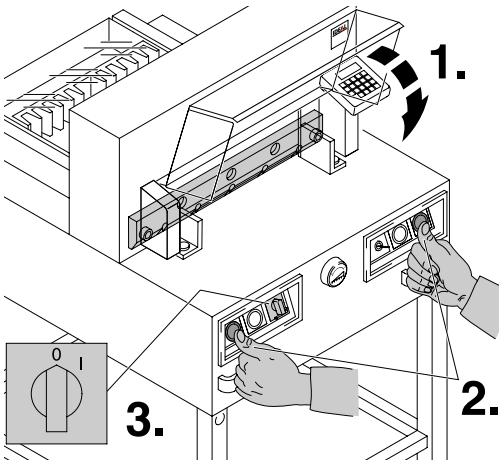

Close the safety guard (1.). Lower the blade by pressing both cutting buttons (2.). Keep one button pressed and turn off the main switch (3.).

IDEAL 4810-95/EP • IDEAL 4850-95/EP • IDEAL 5221-95EP • IDEAL 6550-95EP

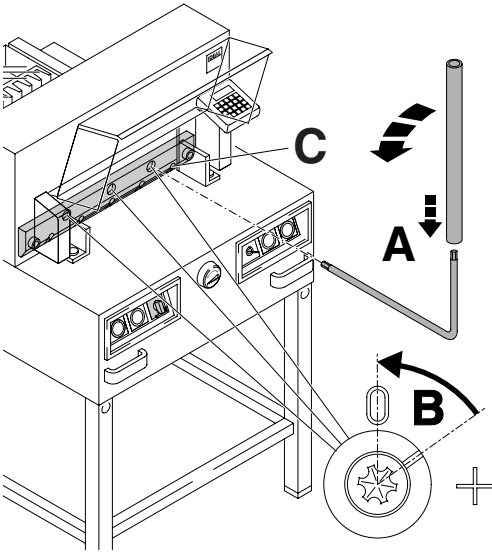

The 3 eccentrics are now exposed and should be turned counter clockwise to position "0" with the special wrench and attachable extension pipe (A) (in the tool set). The slot must correspond to position "0" (B).

Only IDEAL 4810-95/EP, 4850-95/EP
Unscrew the blade screws (C) on the right hand side.

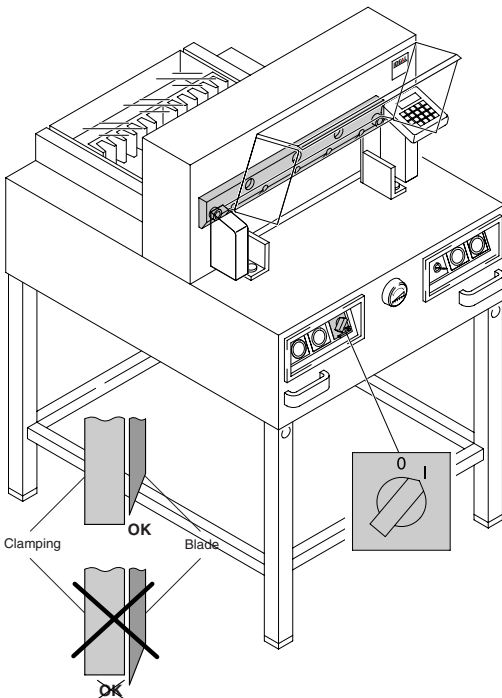

Remove the special wrench and turn on the main switch until the blade returns to the home position.

Warning by IDEAL 4810-95 and IDEAL 4810-95EP

Do not turn main switch to position "0" whilst blade is moving upwards! The clamp must always overlap the blade!
⚠ Danger! Risk of injury!

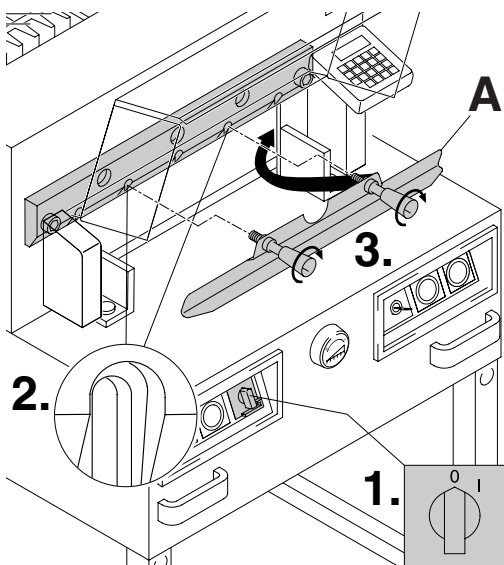

Position the main switch to "0" (1.)
Remove the 2 blade screws on the elongated holes (2.). Then put the blade changing tool (A) into place and fasten it to the blade (3.).

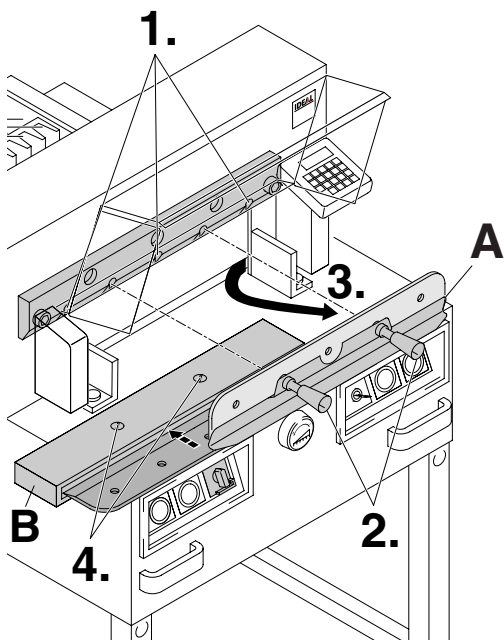

Remove 2 blade screws (1.)
IDEAL 4810-95/EP, IDEAL 4850-95/EP
and 3 blade screws (1.) IDEAL 5221-95EP,
IDEAL 6550-95EP.
Loosen the grips (2.) of the blade changing
tool (A) lightly and allow the blade to be taken
downwards out of the machine (3.). Place the
blade into the blade carrier (B) and screw it
into place (4.).

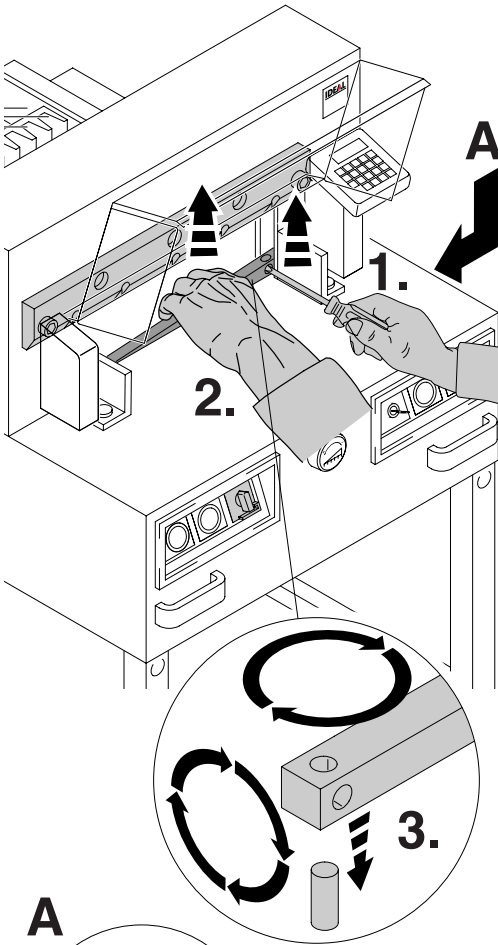

Take out the cutting stick with a small screwdriver. If needed the cutting stick can be turned or exchanged. (The cutting stick can be used eight times).

Replacing the cutting stick (not the blade)

- Turn the blade adjusting screw (A) to the left until it stops. (Otherwise the first cut will be too deep).
- Remove the cutting stick according to top picture.
- Turn the cutting stick (the non-used side must be near to the blade) and plug it into the holding bolt.

⚠ Danger! Risk of injury!

Cutting test after replacing the cutting stick (not the blade)

- Insert the paper and release the cut.
- If the last sheet of paper is not cut along the entire length turn the blade adjusting screw (A) ¼ turn to the right.
- If the last sheet is still not completely cut repeat this process until the last sheet is cut along the entire length.

• Blade and cutting stick replacement •

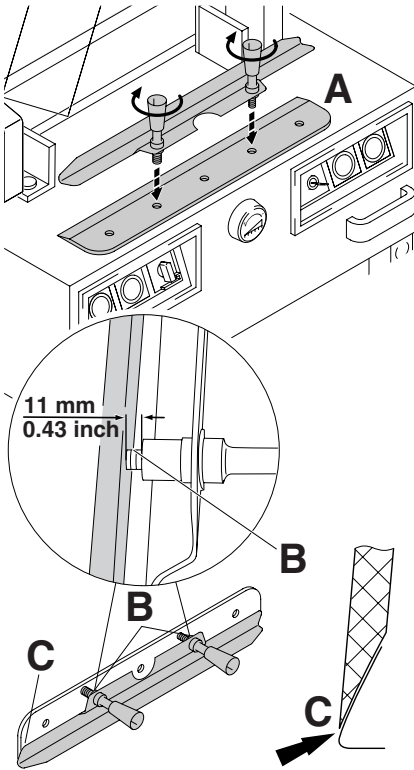

Take the exchange blade carefully out of the blade box and screw it to the blade changing tool (A)

- Make sure there is a space of 11 mm or 0.43 inches! (B).
- Blade must be covered! (C).

⚠ Danger! Risk of injury!

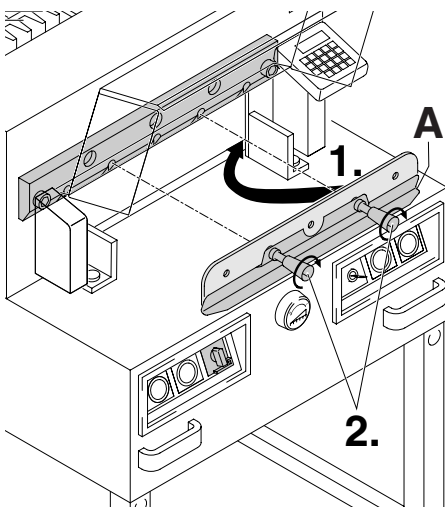

Place the blade to be exchanged with the blade changing tool (A) mounted (1.), into the blade carrier and push it up to the top and screw it into place with the grips (2.).

IDEAL 4810-95/EP • IDEAL 4850-95/EP • IDEAL 5221-95EP • IDEAL 6550-95EP

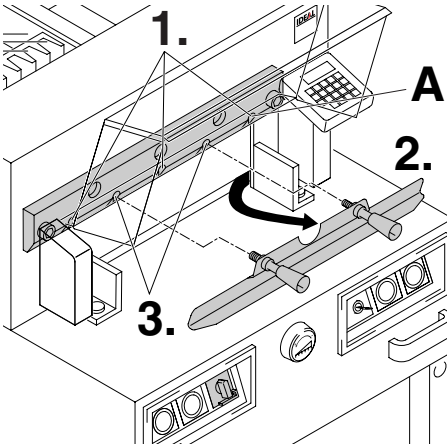

Lightly tighten 3 (IDEAL 4810-95/EP, IDEAL 4850-95/EP has 2) of the 5 blade screws with washers (1.). Remove the blade changing tool (2.). Lightly tighten the remaining blade screws with washers (3.).

IDEAL 4810-95/EP and IDEAL 4850-95/EP
Lightly screw in the right blade screw with the washer (A) when the blade is lowered.

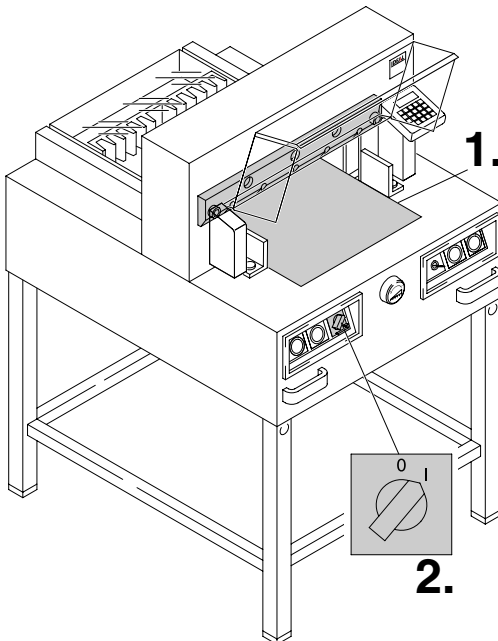

Remove all tools and distribute paper along the entire cutting length (1.).
Turn main switch to position "I" (2.).

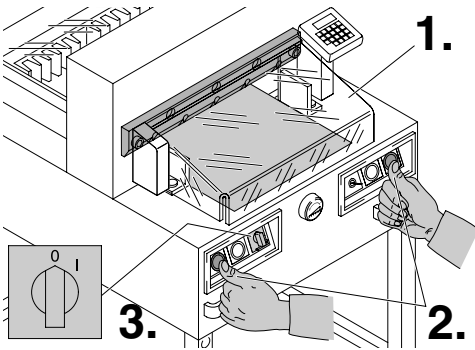

Close the safety guard (1.) Lower the blade by pressing both cutting buttons (2.). Keep one button pressed and turn off the main switch (3.). Open the safety guard (4.). With the special wrench (B) the 3 eccentrics should be screwed down (5.) until the paper is cut along the entire length of the blade (The blade must remain parallel, not too deep into cutting stick).

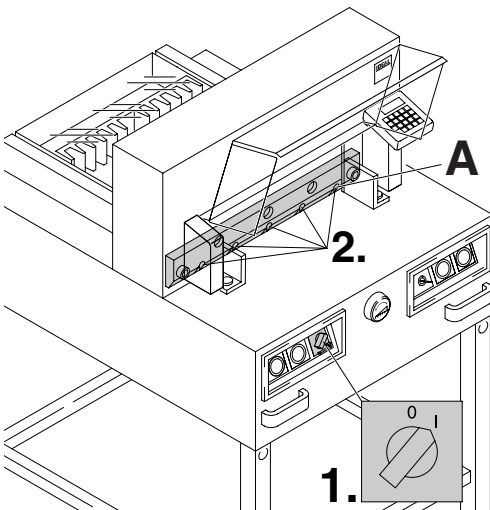
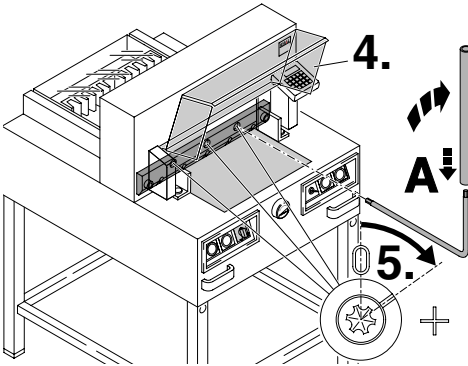

Only IDEAL 4810-95/EP and IDEAL 4850-95/EP

Tighten the blade screws (A) on the right hand side.

Turn main switch to position "I" (1.). Blade will return to upper position. Tighten the blade screws (2.) firmly.

Warning by IDEAL 4810-95 and IDEAL 4810-95EP

Do not turn main switch to position "0" whilst blade is moving upwards! The clamp must always overlap the blade!

⚠ **Danger!** Risk of injury!

IDEAL 4810-95/EP • IDEAL 4850-95/EP • IDEAL 5221-95EP • IDEAL 6550-95EP

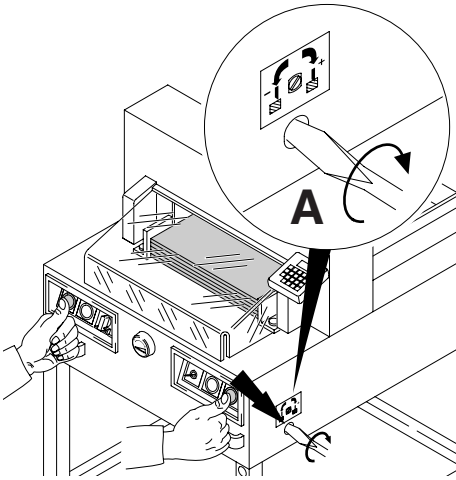

Paper cutting test. If the last sheet or several sheets are not completely cut, gradually turn the knob for blade depth adjustment (A) $\frac{1}{4}$ turn to the right until the paper is cut along the entire length. Do not set too low as blade will become blunt sooner.

Warning by IDEAL 4810-95 and IDEAL 4810-95EP

⚠ Danger!

Blade must always be covered by the pressing bar (see picture below at the left).

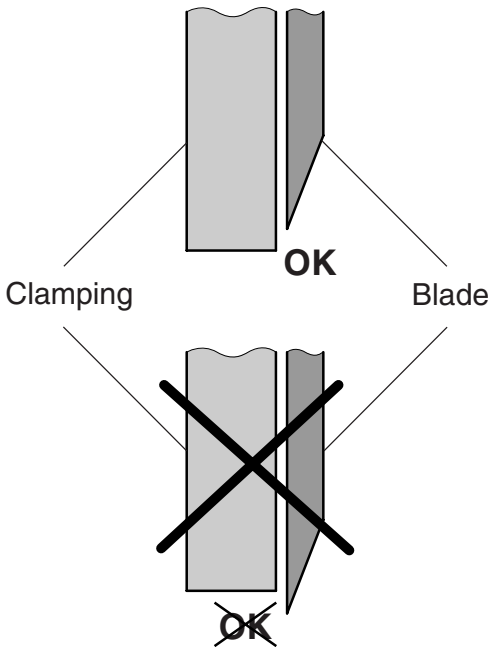

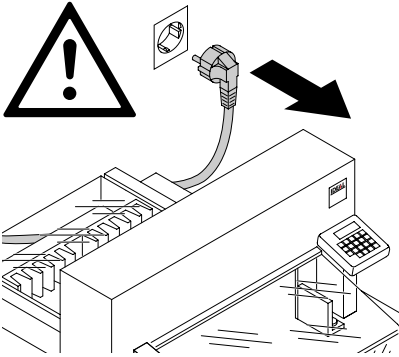

Maintenance work may only be performed by trained staff.

⚠ Danger! Disconnect the mains before starting any service work or before removing the cover.

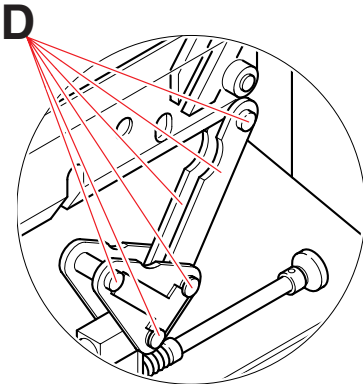

Grease the backgauge (**A**) control weekly with a grease gun. Advance the backgauge as far as possible to the front. (Use non-resinous oil or grease).

Grease the remaining parts twice a year (see picture).

The main switch must be on "0" (**B**).

Remove lower panel and rear wooden panel (**C**). Tools in tool set.

- Remove any paper.
- Grease the machine.
- Check the 4 joining bolts and 2 pushing bars for wear (**D**). If necessary inform your service personnel.
- Mount the machine.

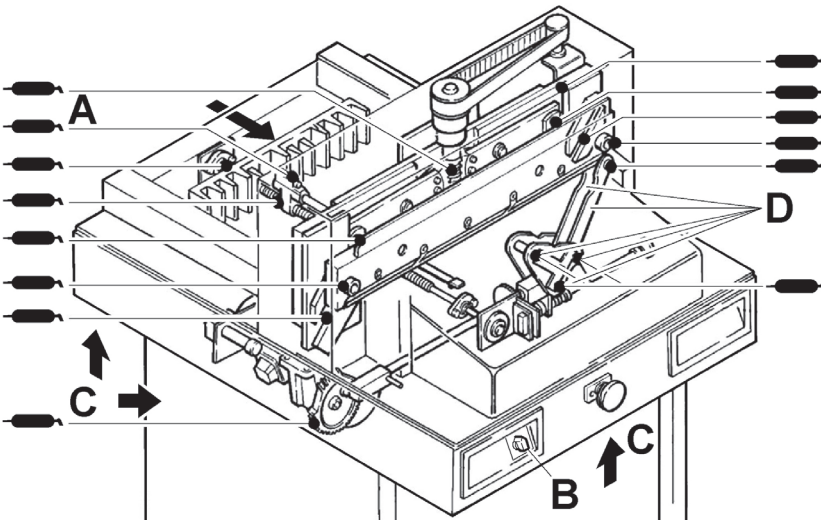

- Maintenance and cleaning •

IDEAL 4810-95/EP • IDEAL 4850-95/EP • IDEAL 5221-95EP • IDEAL 6550-95EP

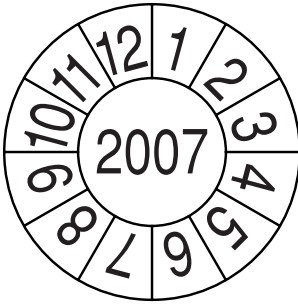

Safety test

The safety regulations are according to the regulations of the country where the cutting machine is operated. The manufacturer recommends a safety check is made every 5 years by an authorised service team.



Machine does not function!

Machine is plugged in?

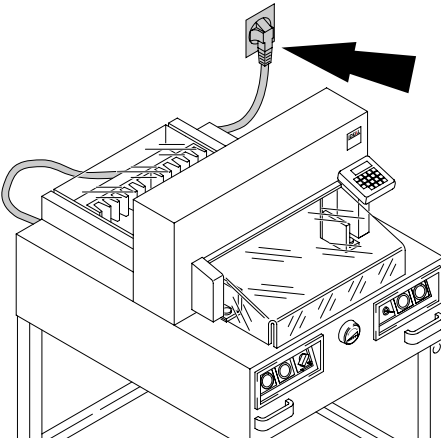

Main switch to position "I"? (A)
Control system activated? (B)
(Turn key to the right)
Release a cut see page 21.

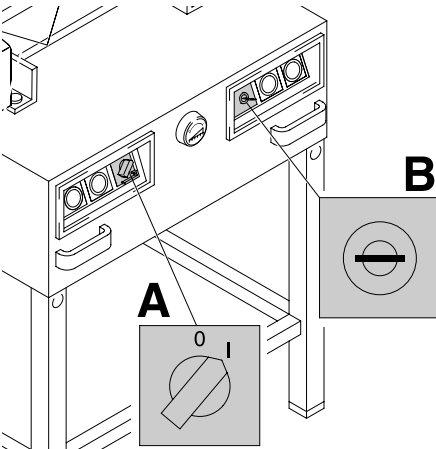

IDEAL 4810-95/EP • IDEAL 4850-95/EP • IDEAL 5221-95EP • IDEAL 6550-95EP

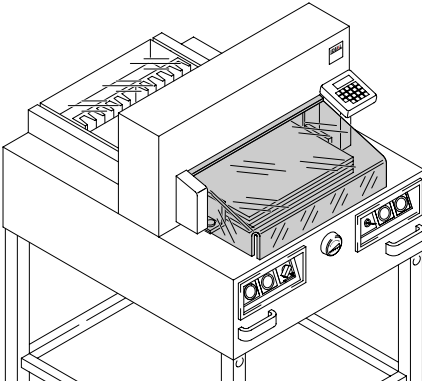

Cut cannot be made.

- If cover is open:
close it.
- If cover is closed:
open and re-close it. (Security check).

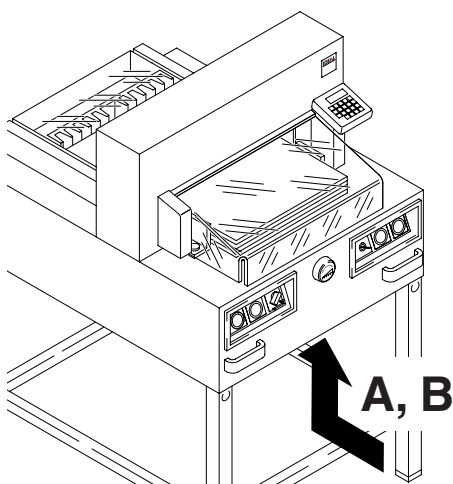

Machine turns off:

- Machine overloaded.
Safety button (A) ejects.
(Allow 1 minute cooling time and reset the safety button (A).
- Machine blocked.
- Blade is blunt.
Eliminate the cause, and push the safety button (A).

Only IDEAL 4810-95EP, IDEAL 4850-95EP IDEAL 5221-95EP, IDEAL 6550-95EP

- Backgauge blocked
Safety button (B) ejects.
Eliminate the cause, and push the safety button (B).

Safety button for:



A = Blade drive

A = Clamping drive

B = Backgauge drive

IDEAL 4810-95/EP • IDEAL 4850-95/EP • IDEAL 5221-95EP • IDEAL 6550-95EP

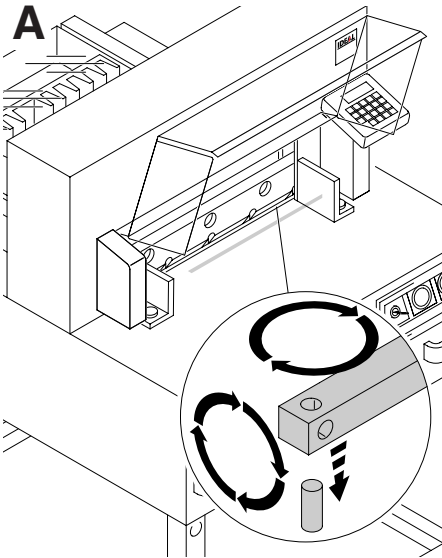

Does not cut through the last sheet:

- Turn or turn around the cutting stick (A), readjust the blade by means of the blade adjusting knob (B) (see page 36).

Poor cutting quality or blade stays in the paper stack.

- Change the blade (C) (see pages 28 - 36).

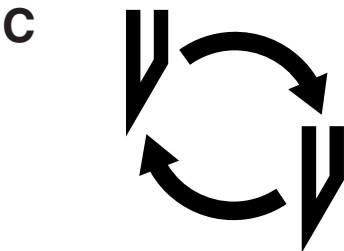
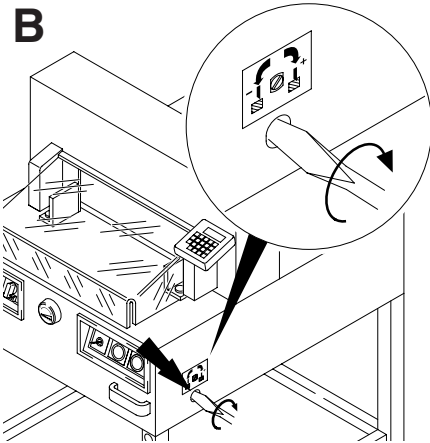

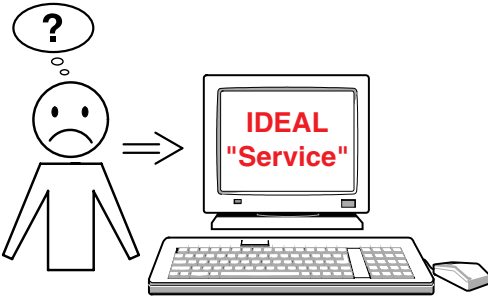

Motor runs but blade does not move downwards.

- Security brake has been activated!
Inform the Service Team!
www.ideal.de → "Service"
service@krug-priester.com

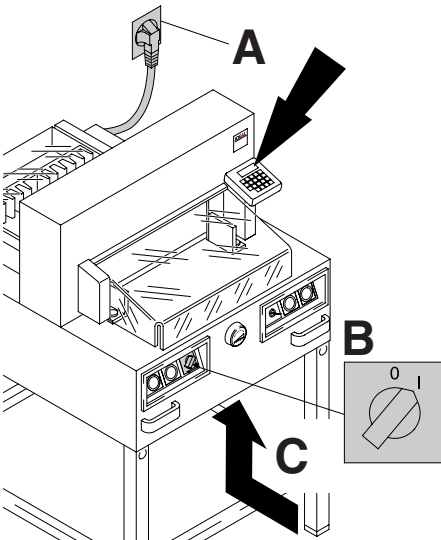

Display illumination off

- Machine is plugged in? (A)
- Main switch on position "I"? (B)
- Push in the safety button! (C)
- Check the units fuse and the on-site circuit breaker!

IDEAL 4810-95/EP • IDEAL 4850-95/EP • IDEAL 5221-95EP • IDEAL 6550-95EP

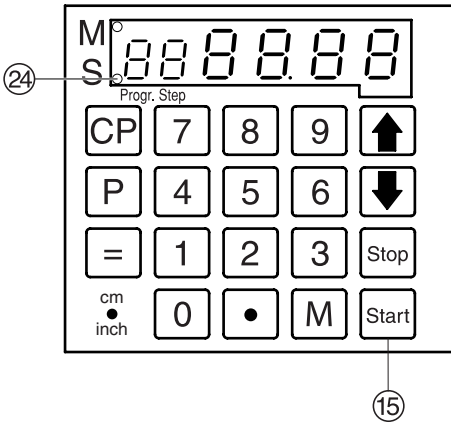

IDEAL 4810-95EP, IDEAL 4850-95EP, IDEAL 5221-95EP, IDEAL 6550-95EP
Cut cannot be made.

- Measurement has not been reached correctly.
- LED "S" ⑳ does not turn off.
Push the **Start** button again.
Check the security cover (see page 40).
- Measurement below 9 cm
Hold the **Start** button ⑮ until the measurement is achieved.

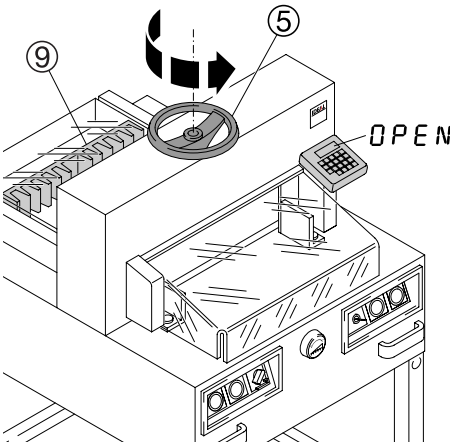

Only IDEAL 4810-95EP

- Backgauge ⑨ does not move and "OPEN" is shown on the display.
Open the clamp ⑤.
Turn the hand wheel to the left as far as possible.
- Backgauge ⑨ does not advance to position (Hand-wheel has been turned to the left).
"OPEN" is shown on the display.
→ inform service people.

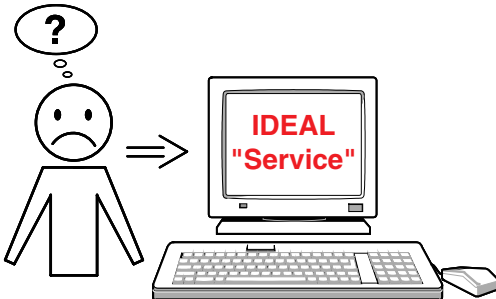

None of the above mentioned methods helped to solve the problem:

Contact Service Team under

- www.ideal.de → "Service"
- service@krug-priester.com

Recommended accessories:

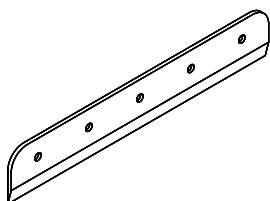

Blade

- Nr. 9000 021 IDEAL 4810-95/EP
- Nr. 9000 021 IDEAL 4850-95/EP
- Nr. 9000 130 IDEAL 5221-95EP
- Nr. 9000 025 IDEAL 6550-95/EP

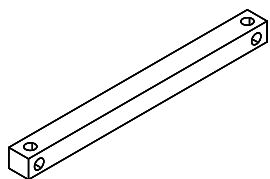

Cutting stick (6 pieces)

- Nr. 9000 022 IDEAL 4810-95/EP
- Nr. 9000 022 IDEAL 4850-95/EP
- Nr. 9000 024 IDEAL 5221-95EP
- Nr. 9000 026 IDEAL 6550-95/EP

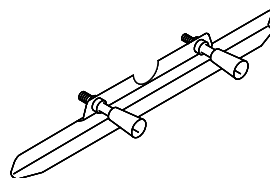

Blade changing tool ¹

- Nr. 9000 511 IDEAL 4810-95/EP
- Nr. 9000 511 IDEAL 4850-95/EP
- Nr. 9000 512 IDEAL 5221-95EP
- Nr. 9000 513 IDEAL 6550-95/EP

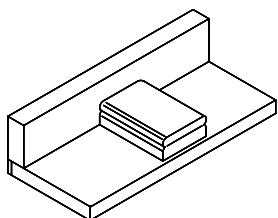

Paper knock-up block ¹

- Nr. 9000 521 IDEAL 4810-95/EP
- Nr. 9000 521 IDEAL 4850-95/EP
- Nr. 9000 521 IDEAL 5221-95EP
- Nr. 9000 521 IDEAL 6550-95/EP

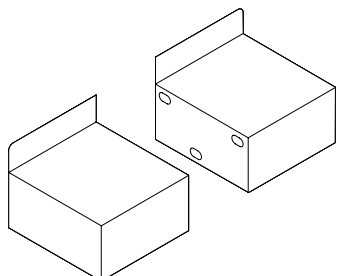

Side tables left and right

- Nr. 9000 530 IDEAL 5221-95EP

¹ Included in delivery

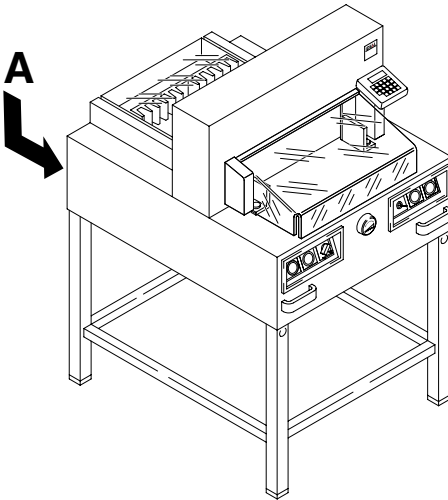

Technical data:

- Power supply: 230V/50Hz/1~, 115V/60Hz/1~
- Cutting length:
475^{1,2,3,4} mm, 520⁵ mm, 650⁶ mm
- Cutting height: 80 mm
- Table depth: 458¹ mm, 450² mm, 458³, 450⁴,
520⁵ mm, 610⁶ mm
- Sound level EN 13023: 71 dB (A)
- Minimum space requirement (width x depth x height)
755^{1,2,3,4} / 855⁵ / 1560^{5,(7)} / 995⁶ mm x 970^{1,2,3,4} /
1067⁵ / 1260⁶ mm x 1360^{1,2} / 1230^{3,4} / 1260⁵ /
1220⁶ mm
- Weight: 194¹, 200², 209³, 215⁴, 262⁵ / 276^{5,(7)},
304⁶ kg

The exact technical specifications can be found on the technical specifications sticker on the machine (A).

- ¹ IDEAL 4810-95
- ² IDEAL 4810-95EP
- ³ IDEAL 4850-95
- ⁴ IDEAL 4850-95EP
- ⁵ IDEAL 5221-95EP
- ⁶ IDEAL 6550-95EP
- ⁷ with side tables

QUALITÄTSMANAGEMENTSYSTEM



DQS-zertifiziert nach
DIN EN ISO 9001: 2000
Reg.-Nr. 1489 QM



ITE Listed 802 D

This machine is approved by independent safety laboratories and is in compliance with the EC-regulations 98/37, 73/23 and 89/336.

Sound level information:

The sound level is 71 db (A) as defined by EN 13023.

Subject to alteration without notice.

D	EG-KONFORMITÄTSERKLÄRUNG
GB	EC-declaration of conformity
F	Déclaration de conformité CE
NL	EG-verklaring van overeenstemming
I	Dichiarazione CE di conformità
E	Declaración CE de conformidad

- Hiermit erklären wir, daß die Bauart von

- Herewith we declare that
- Par la présente, nous déclarons que
- Hiermede verklaren wij, dat de in de handel gebrachte machine
- Si dichiara che il modello della
- Por la presente, declaramos que la

**4810-95 EP; 4850-95 EP; 5221-95 EP; 6550-95 EP;
4810-95; 4850-95**

- folgenden einschlägigen Bestimmungen entspricht

- complies with the following provisions applying to it
- sont conformes aux dispositions pertinentes suivantes
- voldoet aan de eisen van de in het vervolg genoemde bepalingen
- è conforme alle seguenti disposizioni pertinenti
- satisface las disposiciones pertinentes siguientes

EG 98/37; EG 73/23; EG 89/336

- Angewendete harmonisierte Normen insbesondere

- Applied harmonized standards in particular
- Normes harmonisées utilisées, notamment
- Normas armonizadas utilizadas, em particular
- Norme armonizzate applicate in particolare
- Gebruikte geharmoniseerde normen, in het bijzondere
- Normas armonizadas utilizadas particularmente

**EN 60204-1; EN 1010-1; EN 1010-3; EN ISO 61000-3-2; EN ISO 61000-3-3;
EN ISO 12100-1; EN ISO 12100-2; EN 294; EN 954-1; EN 13023;**

Krug & Priester GmbH u. Co KG
72336 Balingen, Germany

22.03.2005
Datum



Wolfgang Priester
- General Manager -



Document Shredders

Trimmers and Guillotines

